

# HORIZONTAL AXIS PEELER CENTRIFUGES TYPE EHL



EHL 16663 DRG

## KEY FEATURES OF EHL TYPE CENTRIFUGES



### PERFORMANCE

- High centrifugal forces.
- Increased productivity.
- Optimized stability.
- Possibility of fully automated cycle.



### ACCESSIBILITY

- Maximal compactness.
- Possibility of ground level installation.
- Clean room installation.
- Full opening housing .



### CLEANABILITY

- Instantaneous and integral visual inspection, housing opened.
- Possibility to “flood wash” the basket .
- Ease of filtration cloth and backing mesh fixing and removing.

# GENERAL DESIGN OF CENTRIFUGES EHLB TYPE

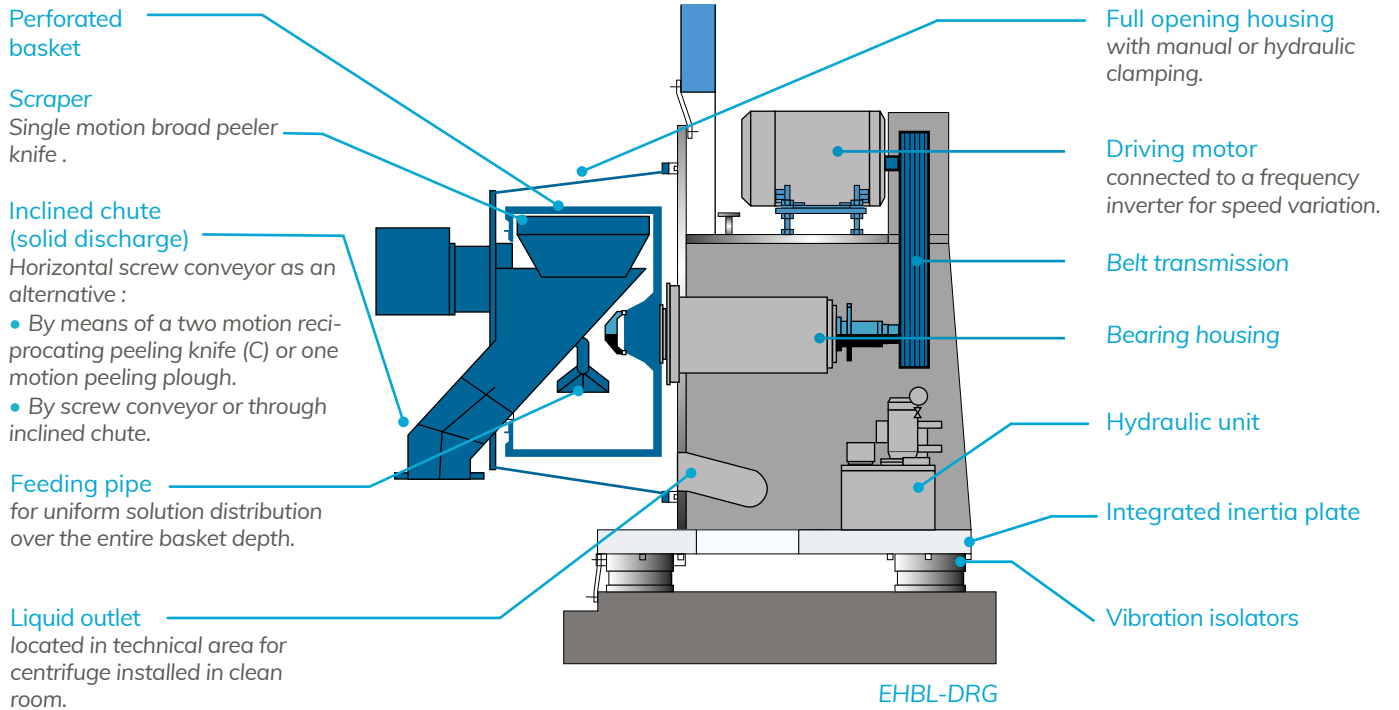

1. Cake washing pipe



2. Residual heel removal device



3. Filtering media applying principle



4. CIP



5. Cake detector

## ADDITIONAL AND OPTIONAL EQUIPMENT

- Cake washing pipe (with spray nozzles)<sup>1</sup>.
- Residual heel removal device (blow-back principle)<sup>2</sup>.
  - Various filtering media fixing systems<sup>3</sup>.
    - CIP (Cleaning In Place)<sup>4</sup>.
  - Cake detector for basket filling optimization (with or without any contact)<sup>5</sup>.
- Materials of construction or coatings, gasket materials.
  - 1 or 3 level vibration sensor.
- Tight or explosion-proof (ATEX in the EU) electrical equipment.
- Vapor tightness for operation under inert gas blanketing.
  - ATEX compliance (for EU), cGMP construction.
- Inerting Control Systems various principles: Pressure control, Oxygen content analysis, Neutral gas inlet flow control.
  - Hydraulic siphon or liquid receiver for liquid outlet tightness.
  - Several possibilities for control systems : from completely manual to fully automatic with local HMI and possibility of plant networking

# MAIN ADVANTAGES OF EHLB TYPE CENTRIFUGES

## Reduced required space for centrifuge location

due to its compactness and the possibility for ground level installation.

## Low remaining moistures

due to high centrifugal forces : Horizontal axis design allow increased rotation speeds, and so boosted "G" effects.

## Full opening casing<sup>1</sup>

(on single or double articulation hinge) giving complete access to the entire process area, which allows for ease maintenance, inspection, cleaning and validation.

Clean room installation possible by "through the wall" separation of processing and technical areas<sup>2</sup>.



Discharging chute with pronounced slope and electro polishing to facilitate cake discharge, easily accessed for cleaning and validation<sup>3</sup>.

Possibility to "flood wash" the basket by partial filling the housing with wash liquors and rotating the basket at low speed.

Feeding of the slurry across the entire length of the basket to ensure uniform cake thickness.

2 • "Through the wall" installation



1 • Full opening casing



3 • Inclined discharging chute



## TECHNICAL CHARACTERISTICS OF EHL CENTRIFUGES

Type EHL	Basket						
	∅ mm	Depth mm	Useful volume L	Maximum load kg	Filtration area m <sup>2</sup>	Maximum speed rpm	Centrifugal force G
EHL 503	500	250	24	30	0.4	2600	1890
EHL 633	630	315	40	50	0.63	2300	1860
EHL 813	810	350	94	120	0.9	2000	1810
EHL 1053	1050	610	220	275	2	1550	1410
EHL 1153	1150	610	330	410	2.2	1400	1260
EHL 1323	1320	720	440	550	3	1235	1130



**HEADQUARTERS**  
 ROUSSELET ROBATEL SA  
 45 Avenue Rhin et Danube  
 Parc d'activité économique de Marenton  
 07104 ANNONAY - FRANCE  
 Tel. : +33 / (0) 4 75 69 22 11  
 Fax : +33 / (0) 4 75 67 69 80  
 E-mail : rousselet.sa@rousselet.com

**UK**  
 Rousselet UK Ltd  
 Parkside House, 17 East Parade  
 HARROGATE  
 NORTH YORKSHIRE HG1 5LF  
 Tel. : + 44 (0)1 423 530 093  
 Fax : + 44 (0)1 423 530 120  
 E-mail : sales@rousselet-robatel.co.uk

**CZECH REPUBLIC**  
 Rousselet Robatel CZ  
 Požernická 96  
 CZ – 108 00 Praha 10  
 Tel. : +420 296 411 402  
 Fax : +420 296 411 403  
 E-mail : info@rousselet.cz

**USA**  
 Robatel Inc.  
 703 West Housatonic Street  
 PITTSFIELD  
 MA 01201  
 Tel. : + 1 413 499 4818  
 Fax : + 1 413 499 5648  
 E-mail : sales@robatel.com